

Agilent 16339A Component Test Fixture  
**Operation and Service Manual**



**Agilent Technologies**

**Agilent Part No. 16339-90010  
Printed in JAPAN January 2000**

**Third Edition**

---

## Notice

The information contained in this document is subject to change without notice.

This document contains proprietary information which is protected by copyright. All rights are reserved. No part of this document may be photocopied, reproduced, or translated to another language without the prior written consent of the Agilent Technologies .

Agilent Technologies Japan, Ltd.  
Component Test PGU-Kobe  
1-3-2, Murotani, Nishi-ku, Kobe-shi,  
Hyogo, 651-2241 Japan

## Warranty

This Agilent Technologies instrument product is warranted against defects in material and workmanship for a period of one year from the date of shipment, except that in the case of certain components listed in this manual, the warranty shall be for the specified period. During the warranty period, Agilent Technologies will, at its option, either repair or replace products which prove to be defective.

For warranty service or repair, this product must be returned to a service facility designed by Agilent Technologies. The Buyer shall prepay shipping charges to Agilent Technologies and Agilent Technologies shall pay shipping charges to return the product to the Buyer. However, the Buyer shall pay all shipping charges, duties, and taxes for products returned to Agilent Technologies from another country.

Agilent Technologies warrants that its software and firmware designed by Agilent Technologies for use with an instrument will execute its programming instruction when properly installed on that instrument. Agilent Technologies does not warrant that the operation of the instrument, or software, or firmware will be uninterrupted or error free.

## Limitation of Warranty

The foregoing warranty shall not apply to defects resulting from improper or inadequate maintenance by the Buyer, Buyer-supplied software or interfacing, unauthorized modification or misuse, operation outside of the environmental specifications for the product, or improper site preparation or maintenance.

*No other warranty is expressed or implied. Agilent Technologies specifically disclaims the implied warranties of merchantability and fitness for a particular purpose.*

## Certification

The Agilent Technologies certifies that this product met its published specifications at the time of shipment from the factory. Agilent Technologies further certifies that its calibration measurements are traceable to the United States National Institute of Standards and Technology, to the extent allowed by the Institute's calibration facility, or to the calibration facilities of other International Standards Organization members.

## **Exclusive Remedies**

*The remedies provided herein are the buyer's sole and exclusive remedies. Agilent Technologies shall not be liable for any direct, indirect, special, incidental, or consequential damages, whether based on contract, tort, or any other legal theory.*

## **Assistance**

Product maintenance agreements and other customer assistance agreements are available for Agilent Technologies products.

If you need assistance, contact your nearest Agilent Technologies Sales and Service Office. Addresses are provided at the back of this manual.

---

## Manual Printing History

The manual printing date and part number indicate its current edition. The printing date changes when a new edition is printed. (Minor corrections and updates which are incorporated at reprint do not cause the date to change.) The manual part number changes when extensive technical changes are incorporated.

December 1991 ..... First Edition (part number: 16339-90000)  
July 1999 ..... Second Edition (part number: 16339-90010)  
January 2000 ..... Third Edition (part number: 16339-90010)

---

## Safety Summary

The following general safety precautions must be observed during all phases of operation, service, and repair of this instrument. Failure to comply with these precautions or with specific **WARNINGS** elsewhere in this manual may impair the protection provided by the equipment. In addition it violates safety standards of design, manufacture, and intended use of the instrument.

*The Agilent Technologies assumes no liability for the customer's failure to comply with these requirements.*

---

### Note



16339A is designed for use in INSTALLATION CATEGORY I according to IEC 61010-1 and POLLUTION DEGREE 1 according to IEC 61010-1 and IEC 60664-1. 16339A is an INDOOR USE product.

---

### Do NOT operate in an Explosive Atmosphere

Do *not* operate the instrument in the presence of flammable gasses or fumes. Operation of any electrical instrument in such an environment constitutes a safety hazard.

### Keep Away from Live Circuits

Operating personnel must not remove instrument covers. Component replacement and internal adjustments must be made only by qualified maintenance personnel. Do not replace components with the power cable connected. Under certain conditions, dangerous voltages may exist even with the power cable removed. To avoid injury, always disconnect power and discharge circuits before touching them.

### Do NOT Service or Adjust While Alone

Do *not* attempt internal service or adjustment unless another person, capable of turning off power and capable of rendering first aid and resuscitation, is present.

### Do NOT Substitute Parts or Modify Instrument

Because of the danger of introducing additional hazards, do *not* substitute parts or perform unauthorized modifications to the instrument. Return the instrument to a Agilent Technologies Sales and Service Office for service and repair to ensure the safety features are maintained.

### Dangerous Procedure Warnings

Warnings, such as the example below, precede **POTENTIALLY DANGEROUS PROCEDURES** throughout this manual. Instructions contained in the **warnings** must be followed.

---

### Warning



**Dangerous voltages, capable of causing death, are present in this instrument. Use extreme caution when handling, testing, and adjusting this instrument.**

---

## Safety Symbols

General definitions of safety symbols used on equipment or in manuals are listed below.



Instruction manual symbol: the product is marked with this symbol when it is necessary for the user to refer to the instruction manual.



Alternating current.



Direct current.



On (Supply).



Off (Supply).

### Warning



This **Warning** sign denotes a hazard. It calls attention to a procedure, practice, condition or the like, which, if not correctly performed or adhered to, could result in injury or death to personnel.

### Caution



This **Caution** sign denotes a hazard. It calls attention to a procedure, practice, condition or the like, which, if not correctly performed or adhered to, could result in damage to or destruction of part or all of the product.

### Note



**Note** denotes important information. It calls attention to a procedure, practice, condition or the like, which is essential to highlight.



Affixed to product containing static sensitive devices use anti-static handling procedures to prevent electrostatic discharge damage to component.



Caution, risk of electric shock : Terminals which may be supplied from the interior of the equipment at a voltage exceeding 1 kV, or allow connection to a voltage exceeding 1 kV are marked with this symbol.

# Contents

---

<b>1. General Information</b>	
Introduction . . . . .	1-1
Using the 16339A . . . . .	1-1
Product Description . . . . .	1-1
Accessories Supplied . . . . .	1-2
Operating and Safety Precautions . . . . .	1-2
Service . . . . .	1-2
Specifications . . . . .	1-2
Supplemental Performance Characteristics . . . . .	1-3
<b>2. Preparation for Use</b>	
Introduction . . . . .	2-1
Initial Inspection . . . . .	2-1
Ambient Environmental Considerations . . . . .	2-3
Operating and Storage . . . . .	2-3
Connecting the Adapter for Use . . . . .	2-3
Exchanging the Component Module . . . . .	2-4
Configuring the Component Module . . . . .	2-5
Repackaging the Adapter . . . . .	2-5
<b>3. Operation</b>	
Introduction . . . . .	3-1
OPEN Correction . . . . .	3-3
Axial Lead Module . . . . .	3-3
SMD Module . . . . .	3-4
Alligator Clip . . . . .	3-5
To Measure A High Capacitance DUT . . . . .	3-6
Checking Procedure . . . . .	3-9
<b>4. Service</b>	
Introduction . . . . .	4-1
General Information . . . . .	4-2
Assembly Replacement (Main Body) . . . . .	4-3
Disassemble and Assemble Procedure . . . . .	4-3
Top Cover Removal . . . . .	4-3
Micro Switch Adjustment . . . . .	4-3
Replaceable Parts . . . . .	4-4
Assembly Replacement (Axial Lead Module) . . . . .	4-8
Replaceable Parts . . . . .	4-8
Assembly Replacement (SMD Module) . . . . .	4-9
Disassembly and Assembly Procedure . . . . .	4-9
Replaceable Parts . . . . .	4-10
Troubleshooting . . . . .	4-11
Cable Connection Check . . . . .	4-11
BNC Cable and Triaxial Cable Connection Check . . . . .	4-11
Interlock Circuit Connection Check . . . . .	4-12

Schematic Diagram . . . . .	4-13
-----------------------------	------



# Figures

---

2-1. Product Overview . . . . .	2-2
2-2. Connecting the Adapter . . . . .	2-3
2-3. Setting Component Module . . . . .	2-4
2-4. Removing the Component Module . . . . .	2-4
2-5. Component Module Configurations . . . . .	2-5
3-1. Appearance (1) . . . . .	3-1
3-2. Appearance (2) . . . . .	3-2
3-3. Appearance(3) . . . . .	3-3
3-4. OPEN compensation for the SMD Module . . . . .	3-4
3-5. OPEN Compensation for Alligator Clips . . . . .	3-5
3-6. Capacitance Measurement Configuration . . . . .	3-7
3-7. Output Resistor Changing Procedure . . . . .	3-8
4-1. Micro Switch Adjustment Screw . . . . .	4-3
4-2. Main Body Replaceable Parts (3 of 3) . . . . .	4-6
4-3. Cable Connection Check . . . . .	4-11
4-4. Schematic Diagram of the 16339A . . . . .	4-13

# Tables

---

1-1. Furnished Accessories . . . . .	1-2
2-1. Contents . . . . .	2-2
3-1. Maximum Measurable Capacitance . . . . .	3-6
3-2. Limit Output Resistance for Each Range . . . . .	3-6
3-3. Appropriate Output Resistance for Range . . . . .	3-7
4-1. 16339A Product Overview . . . . .	4-2
4-2. Main Body Replaceable Parts (1 of 3) . . . . .	4-4
4-3. Main Body Replaceable Parts (2 of 3) . . . . .	4-5
4-4. Main Body Replaceable Parts (3 of 3) . . . . .	4-7
4-5. Axial Lead Module Replaceable Parts . . . . .	4-8
4-6. SMD Module Replaceable Parts . . . . .	4-10
4-7. Interlock Circuit Connection . . . . .	4-12



## General Information

---

### Introduction

The purpose of this manual is to enable you to use your Agilent 16339A Component Test Fixture efficiently and confidently. This manual contains both general and specific information. To use the 16339A to perform a specific function (without having to read the entire manual), follow the directions in “Using the 16339A”.

---

### Using the 16339A

The 16339A has been designed to operate specifically with the 4339A High Resistance Meter.

- To install the 16339A, turn to Chapter 2.
- To operate the 16339A, turn to Chapter 3.
- To order replaceable parts for the 16339A, turn to “Assembly Replacement (Main Body)” in Chapter 4.
- To troubleshoot the 16339A, turn to “Troubleshooting” in Chapter 4.

---

### Product Description

The 16339A has been designed to operate specifically with the 4339A High Resistance Meter. The 16339A is used to measure chip, lead, or other types of components. The 16339A has the following features:

- Reduce electrical noise effects by using a shielded case
- Chip and lead components can be measured in a component socket
- High-voltage safety designed using an interlock circuit

---

## Accessories Supplied

The accessories listed in Table 1-1 are supplied with the 16339A:

**Table 1-1. Furnished Accessories**

Description	Part Number	Quantity
Operation and Service Manual	P/N 16339-90010	1

---

## Operating and Safety Precautions

### Service

The voltage levels (up to 1000 V) in this adapter warrants extreme care for operator safety. Service must be performed only by qualified personnel.

---

## Specifications

This section lists the complete 16339A specifications. These specifications are the performance standards and limits against which the 16339A is tested. When shipped from the factory, the 16339A meets the specifications listed in this section.

Measurement Parameter .....	Direct Insulation Resistance
Applicable Test Voltage .....	1000 V maximum
Applicable Test Current <sup>1</sup> .....	10 mA maximum
Applicable Instrument .....	4339A
Interlock Circuit .....	furnished
Cable Length .....	0.8 m
Operating Temperature .....	0 to 55 °C
Operating Humidity .....	≤70% RH (@40°C)
Non-operating Temperature .....	-40 to 70 °C
Non-operating Humidity .....	≤95% RH (@40°C)
Weight .....	2.2 kg

1. Maximum measurable current of the 4339A is 100  $\mu$ A.

---

## Supplemental Performance Characteristics

This section gives supplemental performance characteristics. Supplemental performance characteristics are not specifications, but are typical characteristics included as additional information for the operator. Supplemental performance characteristics are not guaranteed.

Measurement Range <sup>1</sup> .....	$1 \times 10^3$ to $2 \times 10^{16} \Omega$
Leakage Current (When Opened) <sup>2</sup> .....	$\leq 1 \text{ pA}$
Stability of Leakage Current (When Opened) <sup>2</sup> .....	$\leq 0.5 \text{ pA}$
Measurable Component Parts .....	Radial leaded, Axial Leaded, Chip
Measurable DUT Size (with Alligator Clip) .....	$\leq \phi 5 \text{ mm diameter}$
Measurable Chip Size ....	Width:0.5 to 10 mm, Height:0.5 to 10 mm (Diameter:0.5 to 3.0 mm), .....Length:0.1 to 8 mm
Dimensions .....	200 (W) $\times$ 140 (H) $\times$ 230 (D) [mm]

1. After compensation, measurement time is LONG,  $23 \pm 5 \text{ }^\circ\text{C}$ ,  $\leq 50\% \text{ RH}$

2. After 1000 V has been applied for 1 minute, and under the same conditions as 1



## Preparation for Use

---

### Introduction

This chapter explains how to install the Agilent 16339A Component Test Fixture. The topics covered include initial inspection, ambient environmental considerations, connecting the adapter for use, and repackaging the adapter for shipment.

---

### Initial Inspection

The adapter has been carefully inspected electrically and mechanically before being shipped from the factory. It should be in perfect physical condition, no scratches, dents or the like, and it should be in perfect electrical condition. Verify this by carefully performing an incoming inspection to check the adapter for signs of physical damage and missing contents. If any discrepancy is found, notify the carrier and Agilent Technologies. Your Agilent Technologies sales office will arrange for repair and replacement without waiting for the claim to be settled.

1. Inspect the shipping container for damage, and keep the shipping materials until the incoming inspection is completed.
2. Verify that the shipping container contains everything shown in Figure 2-1 and listed in Table 2-1.
3. Inspect the exterior of the 16339A for any signs of damage.

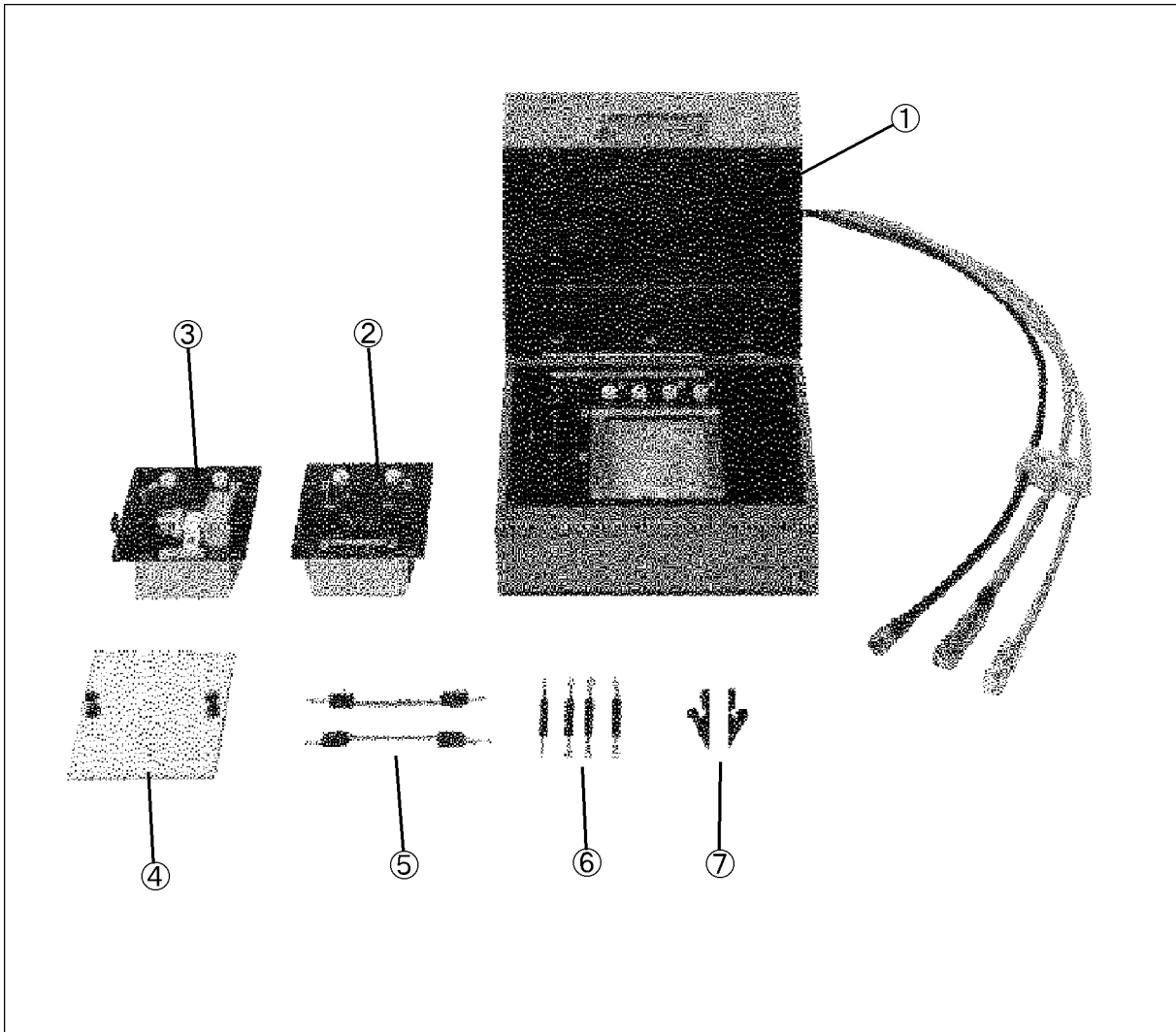

**Figure 2-1. Product Overview**

**Table 2-1. Contents**

	<b>Description</b>	<b>Agilent Part Number</b>	<b>Quantity</b>
①	Component Test Fixture	16339A	1
②	Axial Lead Module	16339-60102	1
③	SMD Module	16339-60101	1
④	Flat Table	16339-60103	1
⑤	Miniature Banana-Plug Cable	16339-61621	2
⑥	100 k $\Omega$ Output Resistor	16339-61001	1
	1 M $\Omega$ Output Resistor	16339-61002	1
	10 M $\Omega$ Output Resistor	16339-61003	1
	100 M $\Omega$ Output Resistor	16339-61004	1
⑦	Alligator Clip	8710-1984	2
⑧	Carrying Case <sup>1</sup>	16339-60011	1
⑨	Operation and Service Manual <sup>1</sup>	16339-90020	1

<sup>1</sup> Carrying Case and Operation and Service Manual is not shown in Figure 2-1.

## 2-2 Preparation for Use



---

## Ambient Environmental Considerations

### Operating and Storage

The 16339A must be operated within an ambient temperature range of 0°C to +55°C and relative humidity up to 70% RH at 40°C (non-condensing).

The 16339A may be stored within a temperature range of -40°C to +70°, and at a relative humidity up to 95% at +40°C (non-condensing).

---

## Connecting the Adapter for Use

Connect the 16339A to the 4339A, as shown in Figure 2-2. You must connect the BNC, triaxial, and interlock connectors. If the interlock connector is not connected, the 4339A will not output the source voltage.

---

### Warning



**Do NOT touch the electrode and UNKNOWN connector while the High Voltage indicator is lit which shows the 4339A's output is a high voltage of up to 1000 Vdc maximum. You must operate after turning off the voltage source output and you have confirmed the high voltage indicator is turned off.**

---

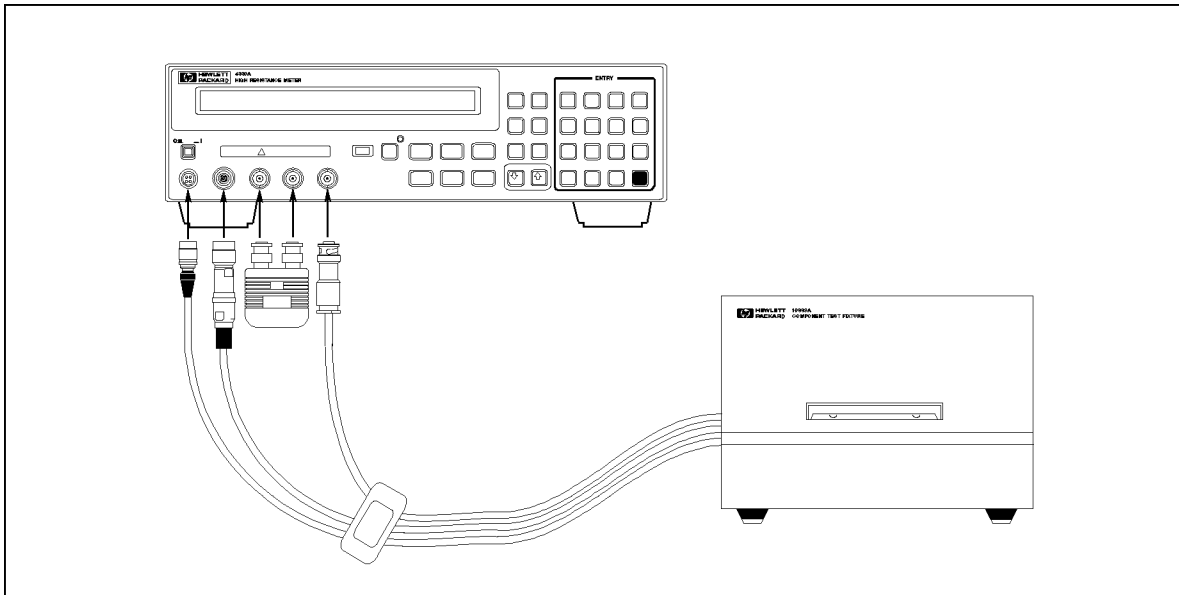

L5006002

Figure 2-2. Connecting the Adapter

---

## Exchanging the Component Module

The 16339A has three types of component modules. The following procedure describes how to set and remove a component module.

---

### Warning



Do NOT touch the electrode and UNKNOWN connector while the High Voltage indicator is lit which shows the 4339A's output is a high voltage of up to 1000 Vdc maximum. You must operate after turning off the voltage source output and you have confirmed the high voltage indicator is turned off.

---

### Component Module Setting Procedure

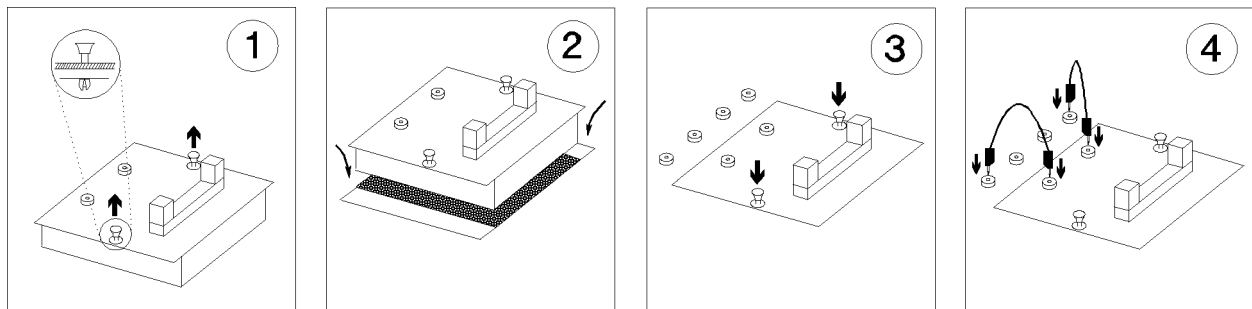

Figure 2-3. Setting Component Module

1. Pull the clamps up.
2. Insert the component module
3. Push the clamps down.
4. Connect the miniature banana cables.

### Component Module Removal Procedure

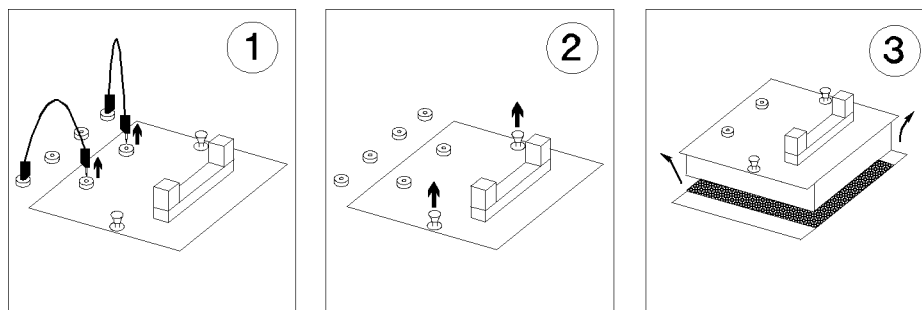

Figure 2-4. Removing the Component Module

1. Disconnect the miniature banana cables.
2. Pull the clamps up.
3. Remove the component module.

## Configuring the Component Module

The 16339A has three types of the component modules. The configuration for each module is shown in Figure 2-5.

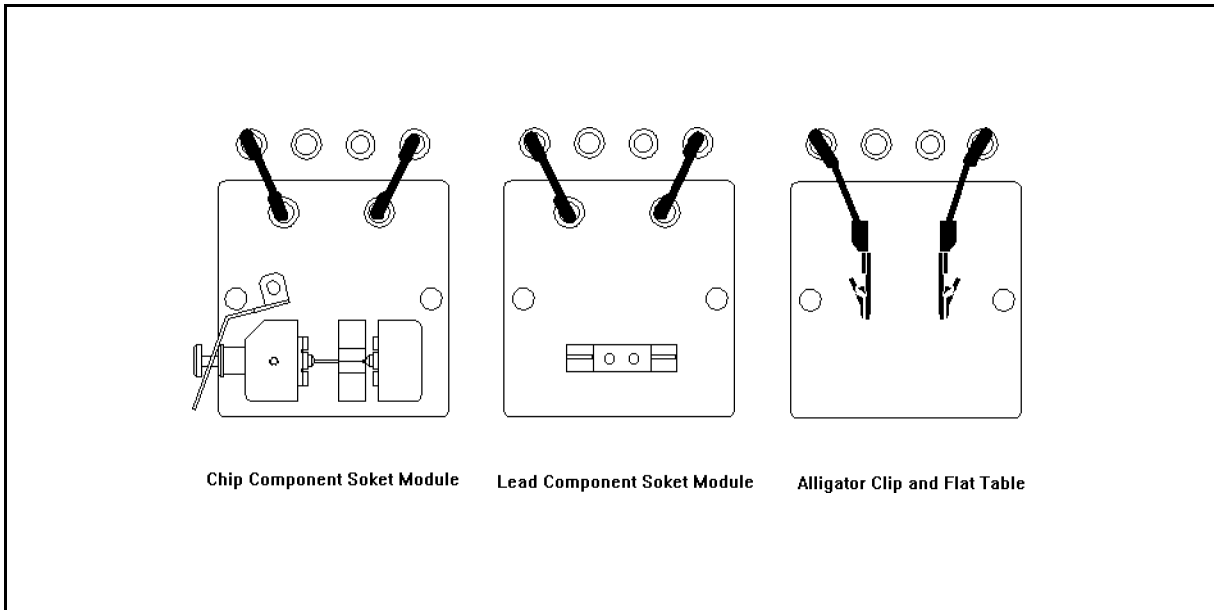

Figure 2-5. Component Module Configurations

---

## Repackaging the Adapter

If shipment to a Agilent Technologies service center is required, each adapter should be repackaged using the original factory packaging materials.

Alternatively, comparable packaging materials may be used. Wrap the adapter in heavy paper and pack in anti-static plastic packing material. Use sufficient shock absorbing material on all sides of the 16339A to provide a thick, firm cushion and to prevent movement. Seal the shipping container securely and mark it *FRAGILE*.



## Operation

### Introduction

This chapter describes the features of the 16339A(Figure 3-1), and connecting a DUT to the 4339A.

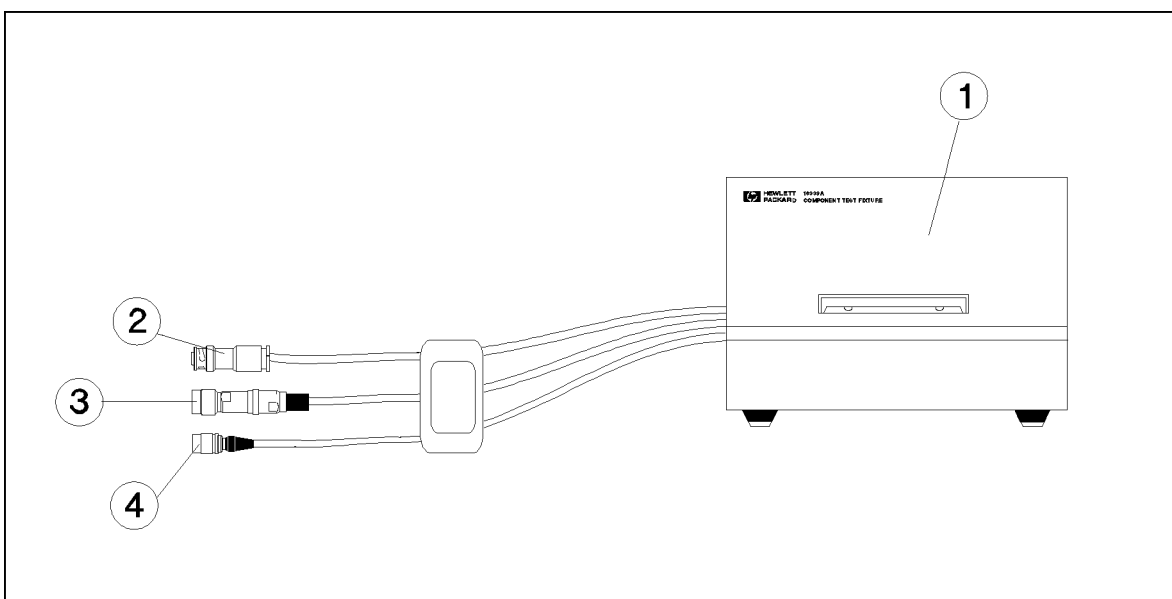

A9003001

**Figure 3-1. Appearance (1)**

1. *Top cover:* This shields against external electrical noise and provides an interlock to enable and disable the test voltage when CLOSED and OPEN respectively.
2. *BNC connector:* This connector provides the source voltage to the 16339A.
3. *Triaxial connector:* The measured signal is carried on the center conductor of this connector.
4. *Interlock connector:* This connector enables the interlock function which enables and disables applying the source voltage from the 4339A when the top cover is CLOSED and OPEN respectively. When the shield case is OPEN, the source voltage is turned OFF inside the 4339A.

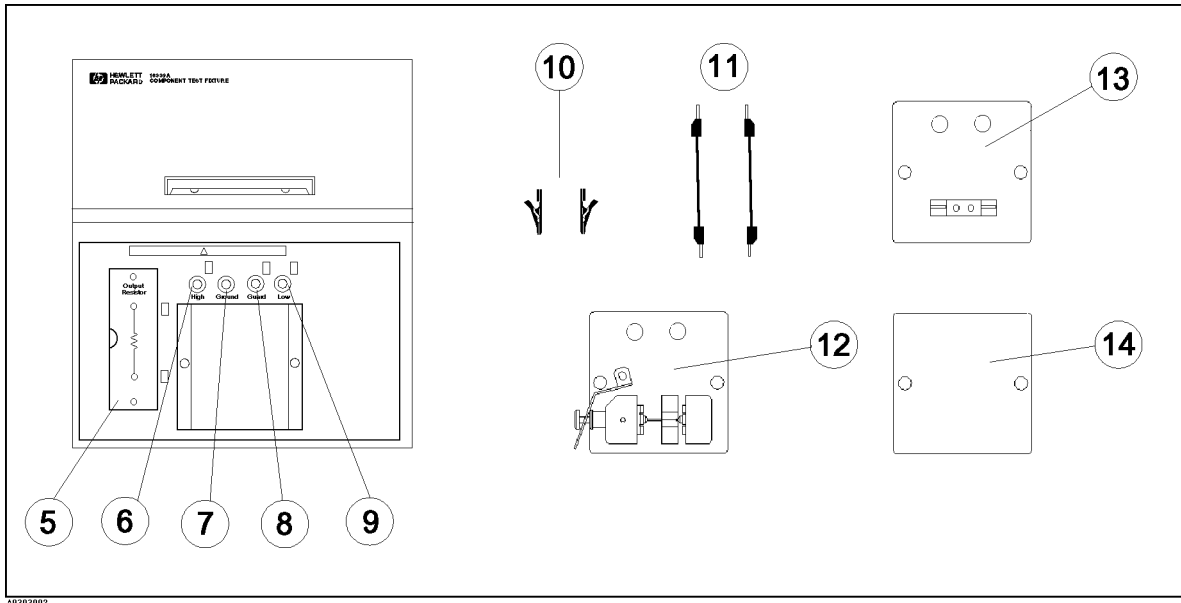

**Figure 3-2. Appearance (2)**

5. *Output Resistor Cover.* Output resistor of the 16339A can be changed for measuring high capacitance DUTs. For details about the output resistor, refer to “To Measure A High Capacitance DUT”.
6. *High terminal.* This terminal provides a source voltage of up to 1000 V. This terminal is connected to the center conductor of the BNC connector.
7. *Ground terminal.* This terminal is connected to ground which is the outer shield of the triaxial and BNC connectors.
8. *Guard terminal.* This terminal is connected to the guard which is the inner shield of the triaxial connector.
9. *Low terminal.* This terminal is the measured current path, and is connected to center conductor of the triaxial connector.
10. *Alligator clip.* This is used to measure components which can not be measured using axial lead module or SMD module.
11. *Miniature banana-plug cable.* This cable interconnects the component socket module and the 16339A.
12. *SMD module.* This is used to measure chip components.
13. *Axial Lead module.* This is used to measure components with leads.
14. *Flat table.* This is used when using alligator clips. This table is made of Teflon.

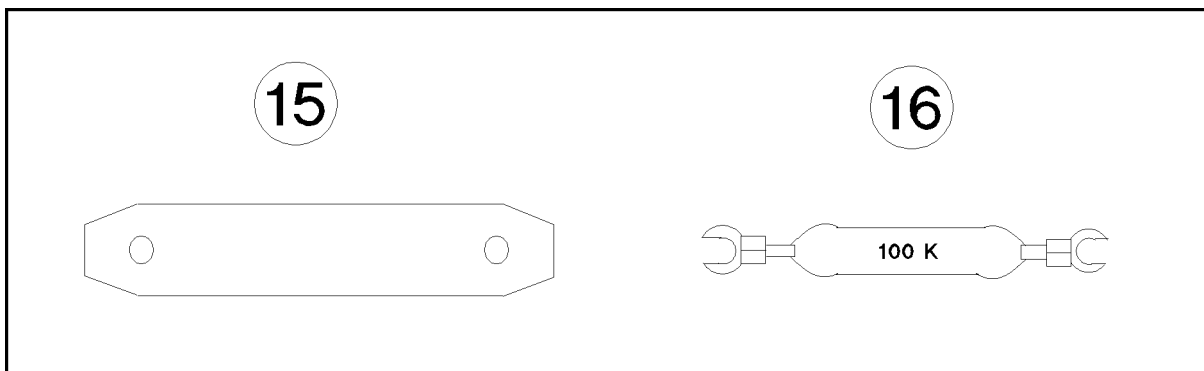

A9003009

**Figure 3-3. Appearance(3)**

15. *Short Bar* Normally, this shorting bar is connected in output resistor cover.
16. *Output Resistor* There are four exchangeable output resistors for the 16339A. Indicated number shows its resistance:
- 100 K means 100 k $\Omega$
  - 1 M means 1 M $\Omega$
  - 10 M means 10 M $\Omega$
  - 100 M means 100 M $\Omega$

For details about output resistors, refer to “To Measure A High Capacitance DUT”.

## OPEN Correction

OPEN correction cancels the residual inductance for resistance measurements. The procedure for each component socket module is as follows:

### Axial Lead Module



When using the axial lead module, the OPEN correction procedure is:

#### Warning



**Do NOT touch the electrode and UNKNOWN connector while the High Voltage indicator is lit which shows the 4339A's output is a high voltage of up to 1000 Vdc maximum. You must operate after turning off the voltage source output and you have confirmed the high voltage indicator is turned off.**

### OPEN Correction Procedure

1. Remove DUT if connected.
2. Close the top cover.
3. Select current measurement mode at 4339A.
4. Apply the source voltage required for your measurement at the 4339A.
5. Wait until the current has stabilized to within 0.5 pA.
6. Press   keys of the 4339A to perform the OPEN correction.

## SMD Module

When using the SMD module, the OPEN correction procedure is:

### Warning



Do NOT touch the electrode and UNKNOWN connector while the High Voltage indicator is lit which shows the 4339A's output is a high voltage of up to 1000 Vdc maximum. You must operate after turning off the voltage source output and you have confirmed the high voltage indicator is turned off.

### Open Correction Procedure

1. Remove DUT if connected, and leave the SMD module electrode contact spacing the same as the DUT's spacing as shown in Figure 3-4
2. Tighten the screw to hold the interval between the electrodes.

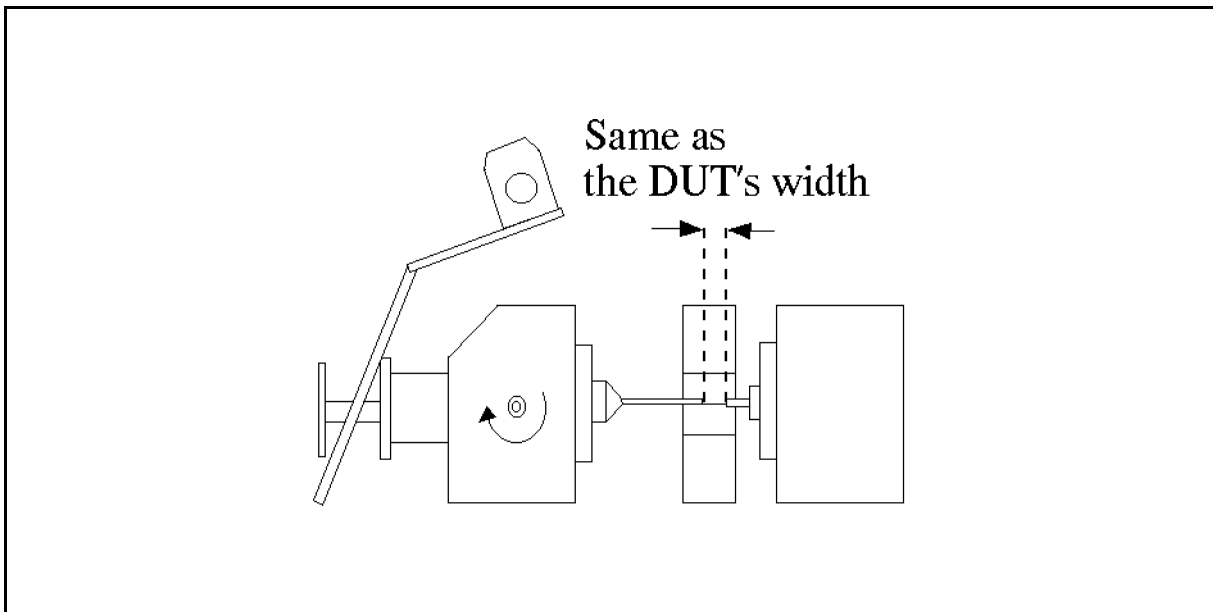



Figure 3-4. OPEN compensation for the SMD Module

3. Close the top cover.
4. Select the current measurement mode at the 4339A.
5. Set and apply the source voltage required for your measurement at the 4339A.
6. Wait until the current has stabilized to within 0.5 pA.
7. Press   keys of the 4339A to perform the OPEN correction.

### Note



Keep the chip contact area clean, because any contamination will degrade measurement accuracy. To keep the chip contact area clean, avoid touching this area with your bare hands and use clean insulated tweezers when inserting and removing chip components.



## Alligator Clip

When using the alligator clips, the recommended OPEN correction procedure is as follows:

### Warning





**Do NOT touch the electrode and UNKNOWN connector while the High Voltage indicator is lit which shows the 4339A's output is a high voltage of up to 1000 Vdc maximum. You must operate after turning off the voltage source output and you have confirmed the high voltage indicator is turned off.**

### Open Correction Procedure

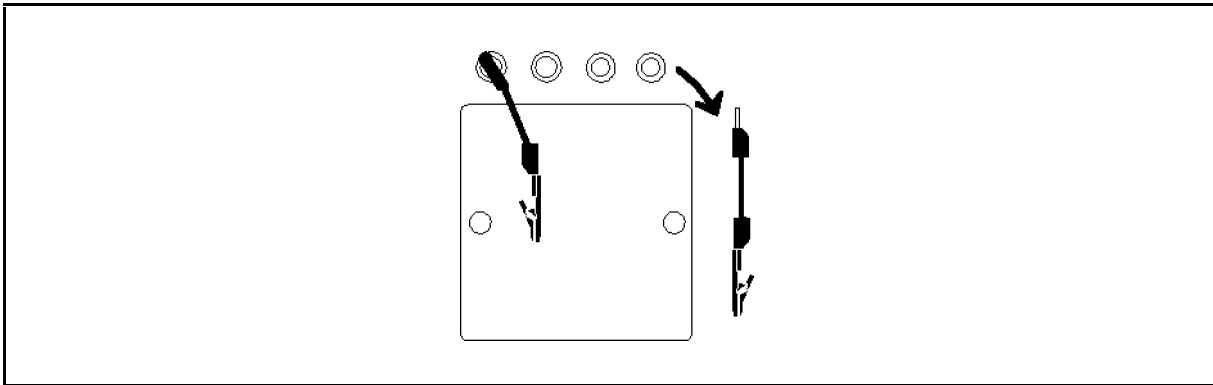
1. Remove the alligator clips and banana cables from the INPUT terminal as shown in Figure 3-5.



**Figure 3-5. OPEN Compensation for Alligator Clips**

2. Close the top cover.
3. Select the current measurement mode at the 4339A.
4. Set and apply source voltage required for your measurement at the 4339A.
5. Wait until the current has stabilized to within 0.5 pA.
6. Press   keys of the 4339A to perform the OPEN correction.

---

## To Measure A High Capacitance DUT

When the 4339A measures a high capacitance DUT, AC noise creates major instability factors in the measurement. When you measure a high capacitance DUT, measurement result will not stable. This due to the capacitance is sensitive for AC noise. If you want to measure resistance of capacitor with keeping more than 10 % of S/N ratio, the maximum measurable capacitance of the DUT for each measurement range are listed in Table 3-1.

**Table 3-1. Maximum Measurable Capacitance**

Measurement Range	Measurement Time		
	Short	Medium	Long
100 pA	—	1 nF	10 nF
1 nA	1 nF	10 nF	100 nF
10 nA	10 nF	100 nF	1 $\mu$ F
100 nA	100 nF	1 $\mu$ F	10 $\mu$ F
1 $\mu$ A	1 $\mu$ F	10 $\mu$ F	100 $\mu$ F
10 $\mu$ A	10 $\mu$ F	100 $\mu$ F	1 mF
100 $\mu$ A	100 $\mu$ F	—	—

To measure a higher capacitance, connecting a resistor in series with DUT is effective in reducing the measurement flicker. The 16339A's output resistor connected in series with the DUT is exchangeable. The 16339A has four different resistors for output resistor. Ideally, higher series resistance enables more stable measurement. However, there is limitation for improvement of S/N ratio by connecting higher resistance, actually. Following table lists upper limit of the series resistance for each measurement range.

**Table 3-2. Limit Output Resistance for Each Range**

Measurement Range	Output Resistor
100 pA	100 M $\Omega$
1 nA	10 M $\Omega$
10 nA	1 M $\Omega$
$\geq$ 100 nA	100 k $\Omega$

Table 3-3 shows an appropriate resistor for each range when you measure higher capacitance than listed in Table 3-1 with keeping more than 10 % S/N ratio.

**Table 3-3. Appropriate Output Resistance for Range**

Measurement Range	Measurement Time		
	Short	Medium	Long
100 pA	—	10 MΩ(100 MΩ <sup>1</sup> )	10 MΩ(100 MΩ <sup>1</sup> )
1 nA	10 MΩ	1 MΩ	1 MΩ
10 nA	1 MΩ	100 kΩ	100 kΩ
100 nA	100 kΩ	(100 kΩ) <sup>2</sup>	(100 kΩ) <sup>2</sup>
1 μA	(100 kΩ) <sup>2</sup>	Short Bar <sup>3</sup>	Short Bar <sup>3</sup>
10 μA	Short Bar <sup>3</sup>	Short Bar <sup>3</sup>	Short Bar <sup>3</sup>
100 μA	Short Bar <sup>3</sup>	—	—

1 100 MΩ resistor is effective for measuring current less than 10 pA in 100 pA range.

2 Using 100 kΩ resistor is recommended, but the response will become slow.

3 4339A's internal input/output resistance works well enough, so an extra resistor in series is not necessary.

Using a high resistance causes the charging time constant of capacitive DUT to increase, thereby increasing the necessary measurement time.

Figure 3-6 shows simplified measurement configuration when measuring capacitance with series resistance.

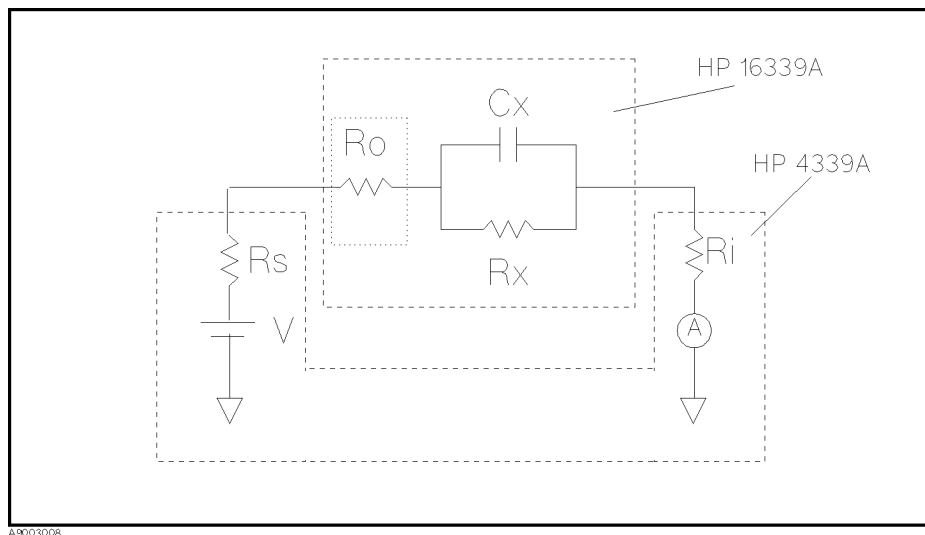

**Figure 3-6. Capacitance Measurement Configuration**

Where,

- Rs Output Resistance of the 4339A
- Rx Parallel resistance of the DUT
- Cx Parallel capacitance of the DUT
- Ri Input resistance of the 4339A
- Ro Additional Series Output Resistance of the 16339A

Necessary charging time is approximately led by following equation.

$$t_c = -\tau \times \ln\left(\frac{X}{100} \times \frac{R_s + R_i + R_o}{R_x}\right)$$

Where,

$t_c$  : charge time [s]

$X$  : Measurement Error [%]

$\tau = C_x \times (R_s + R_i + R_o)$

Generally, when measuring capacitor with as described configuration in this section, you should wait charging time for more than 10 or 20 times  $\tau$ .

### Note



When the additional series resistor value becomes high enough, its resistance can not be disregarded and the resistance of the DUT causes additional measurement error.

Changes output resistor of the 16339A as shown in Figure 3-7.

### Warning



**Do NOT touch the electrode and UNKNOWN connector while the High Voltage indicator is lit which shows the 4339A's output is a high voltage of up to 1000 Vdc maximum. You must operate after turning off the voltage source output and you have confirmed the high voltage indicator is turned off.**

### To Exchange Output Resistor

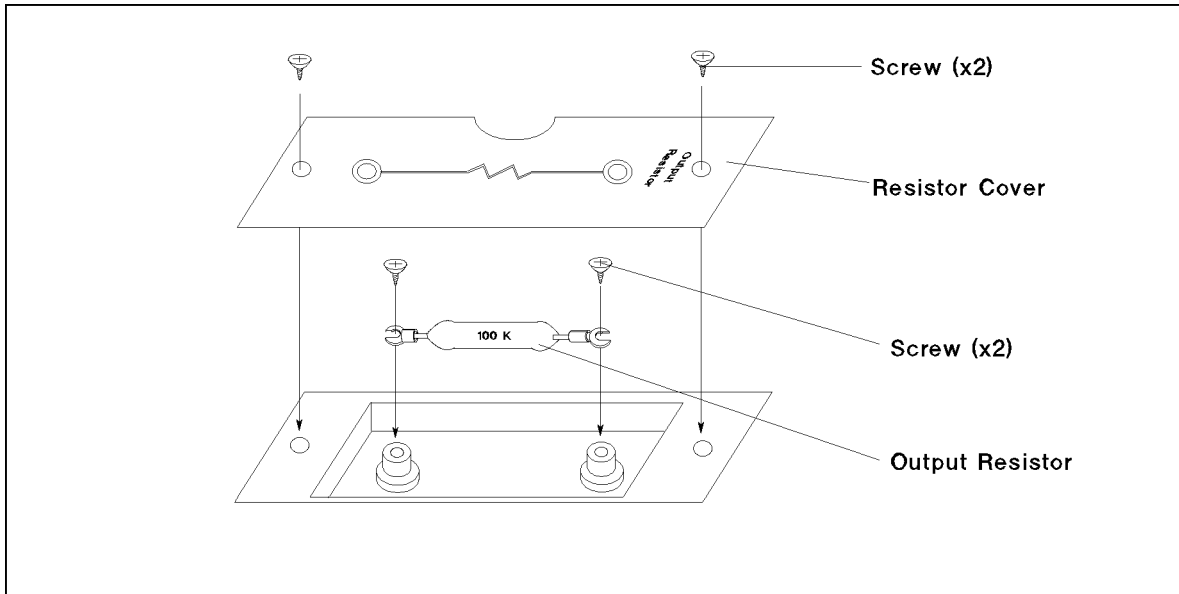

**Figure 3-7. Output Resistor Changing Procedure**

1. Turn OFF the voltage output of the 4339A, if it is turned ON.
2. Open the top cover of the 16339A.
3. Remove the two screws holding the output resistor cover, then remove the output resistor cover.
4. Remove the two screws holding the output resistor.

### 3-8 Operation

5. Remove the internal resistor.
6. Select an appropriate resistor for the measurement range you want to select by using Table 3-3.
7. Place the new output resistor so that the two holes are aligned with the two electrodes.
8. Insert and tighten the two screws to hold the resistor.
9. Close the output resistor cover and refasten with two screws.

---

**Warning**

**Do NOT use an output resistor other than those furnished with the 16339A.**



---

## Checking Procedure

The 16339A and the 4339A is operated with high voltages of up to 1000 V. These products are designed so that the operator can make safe measurements. To maintain this safe condition, you must periodically perform the following safety verification procedure.

---

**Warning**

**Do NOT touch the electrode and UNKNOWN connector while the High Voltage indicator is lit which shows the 4339A's output is a high voltage of up to 1000 Vdc maximum. You must operate after turning off the voltage source output and you have confirmed the high voltage indicator is turned off.**



---

## Daily Safety Verification Procedure

1. Connect the 16339A to the 4339A.
2. Close the top cover of the 16339A.
3. Set source voltage to 42 V.
4. Press the V output key of the 4339A.  
Confirm that the V output indicator and the High Voltage indicator turn on.
5. Open the top cover of the 16339A.  
Confirm that the High Voltage indicator turns off immediately.
6. Close the top cover again.  
Confirm that the High Voltage indicator still turns off.

If you encountered any errors in checking procedure, contact your nearest Agilent Technologies Office.



# Service

---

## Introduction

This chapter gives the service information for the 16339A Component Test Fixture.

This chapter consists of assembly replacement information for each of the main body and socket modules, and troubleshooting information. assembly replacement sections include disassembly and assembly procedures, and replaceable parts lists. The troubleshooting section includes cable connection information and the schematic diagram.

Figure 2-1 shows all items included with the 16339A. Table 4-2, Table 4-3, and Table 4-4 identify the Main Body replaceable parts. Table 4-5 identifies the Axial Lead Module replaceable parts. Table 4-6 identifies the SMD Module replaceable parts.

To order the parts listed in this manual, quote the Agilent part number, indicate the quantity required, and address the order to the nearest Agilent Technologies office.

---

### Warning



**These servicing instructions are for use by qualified personnel only. Do NOT perform any servicing other than that contained in the operating section unless you are qualified to do so.**

---

## General Information

This section includes Figure 2-1 which shows all items included with the 16339A.

**Table 4-1. 16339A Product Overview**

Reference Designator	Agilent Part Number	Qty.	Description
1	16339-60101	1	SMD Module
2	16339-60102	1	Axial Lead Module
3	Not Assigned	1	Main Body
4	8710-1984	2	Alligator Clip
5	16339-61001	1	100 k $\Omega$ Output Resistor
	16339-61002	1	1 M $\Omega$ Output Resistor
	16339-61003	1	10 M $\Omega$ Output Resistor
	16339-61004	1	100 M $\Omega$ Output Resistor
6	16339-61621	2	Miniature Banana-Plug Cable
7	16339-60103	1	Flat Table
	16339-60011	1	Carrying Case <sup>1</sup>
	16339-90020	1	Operation and Service Manual <sup>1</sup>

<sup>1</sup> Not shown in this figure.



---

## Assembly Replacement (Main Body)

This section includes Disassembly and Assembly Procedures and Replaceable Parts for the Main Body.

### Disassemble and Assemble Procedure

This section explains complex and significant points of disassembly and assembly of the main body.

#### Top Cover Removal

Before removing the top cover, the screw, which pushes the micro switch closed, should be removed from the top cover. The screw is accessed by removing the bottom cover, it is mounted on the portion of the top cover which extends down into the box. (See Figure 4-1.)

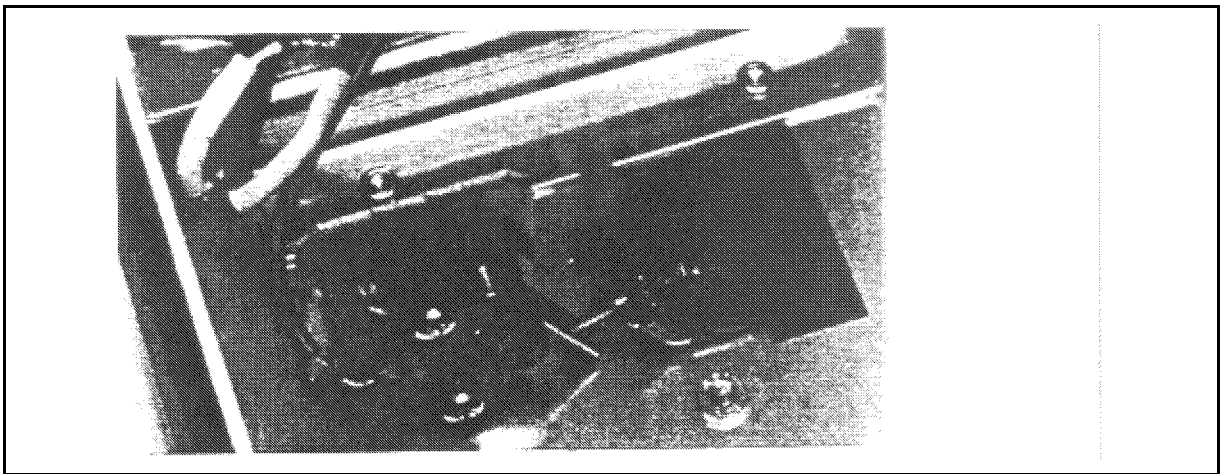

Figure 4-1. Micro Switch Adjustment Screw

#### Micro Switch Adjustment

---

##### Note



When the top cover or the micro switch is reassembled, the length of the screw which pushes the micro switch closed must be adjusted so that it will cause the micro switch to open at the proper top cover opening angle.

---

The micro switch adjustment procedure is as follows:

##### Micro switch adjustment procedure:

1. Put a drop of Lock-Tite (PN 0470-0013) on the screw's threads at the nut.
2. Rotate the screw clockwise until you hear the micro switch click closed and can verify using a low resistance range of a multimeter and see the resistance change when the switch closes.
3. Rotate the screw in one more turn clockwise.
4. Tighten the nut to fix the screw while holding the screw in position with a screw driver.

## Replaceable Parts

Table 4-2, Table 4-3, and Table 4-4 identify the replaceable parts for the main body. To order the parts listed in this manual, quote the Agilent part number, indicate the quantity required, and address the order to the nearest Agilent Technologies office.

**Table 4-2. Main Body Replaceable Parts (1 of 3)**

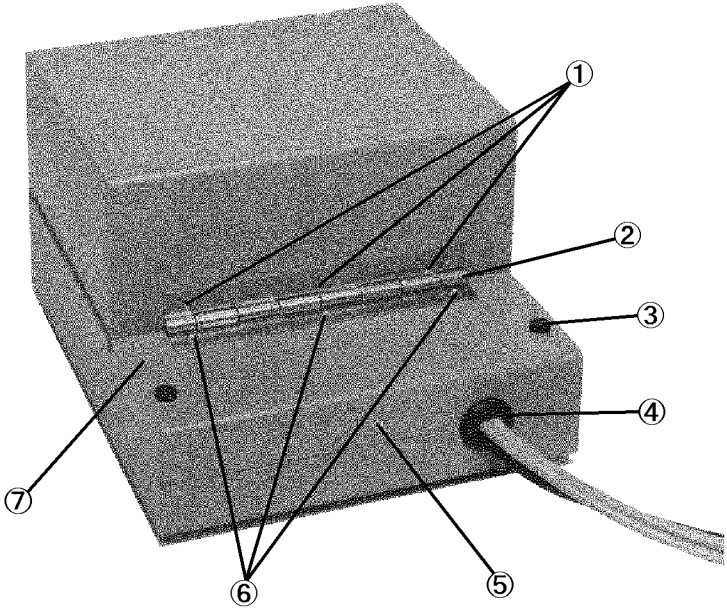

Reference Designator	Agilent Part Number	Qty.	Description
1	0515-0914	3	Screw Flat Head M3 L6
2	16008-09051	1	Hinge
3	0403-0316	2	Bumper FT-PRS-IN
4		1	Bushing
5	0515-0914	1	Screw Flat Head M3 L6
6	0515-0907	3	Screw Flat Head M3 L8
7	16008-00251	1	Panel, Rear

**Table 4-3. Main Body Replaceable Parts (2 of 3)**

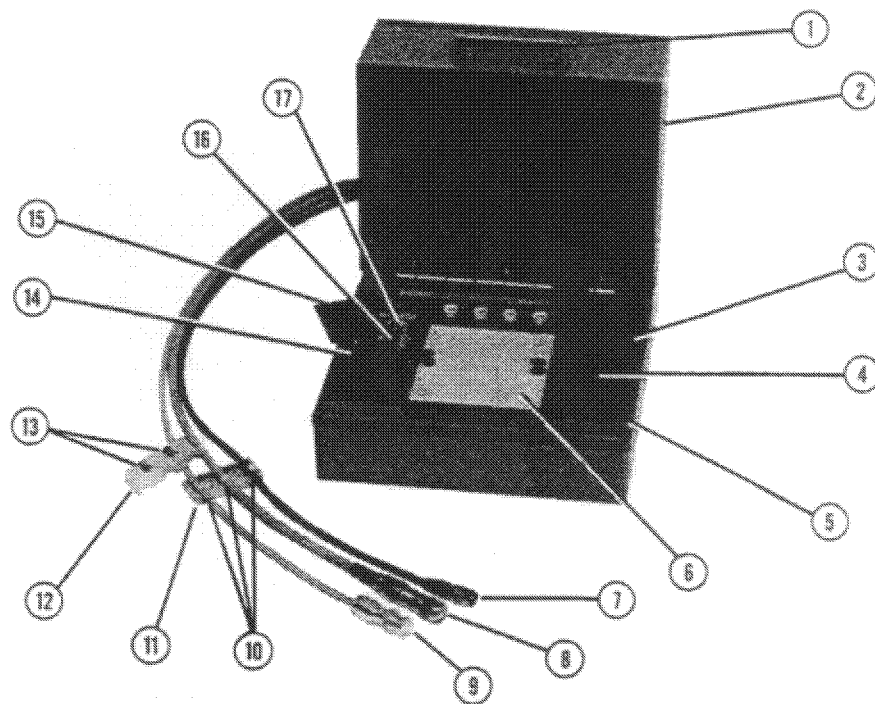

Reference Designator	Agilent Part Number	Qty.	Description
1	16088-40001	1	Knob
	0535-0031	2	Nut (for Knob)
2	16339-60011	1	Top Cover Assembly
3	0515-0907	2	Screw
4	16339-60017	1	Panel Assembly
5	16008-40051	1	Trim
	0515-1550	4	Screw (for Trim) <sup>1</sup>
	3050-0891	4	Washer (for Trim) <sup>1</sup>
6	16339-60103	1	Flat Table
	16339-00207	2	Plate, Teflon <sup>2</sup>
	1390-0365	2	Snap-In Plunger <sup>2</sup>
	0390-0366	2	Snap-In Grommet <sup>2</sup>
7	16339-61653	1	Cable Assembly Interlock
8	16339-61611	1	Cable Assembly Triaxial
9	16339-61612	1	Cable Assembly BNC
10	1400-0249	3	Cable Tie
11	16117-40001	1	Holder, Cable
12	16117-40002	1	Holder, Cable
13	0515-1552	2	Screw
14	16339-00213	1	Lid, Output Resistor
15	0515-0914	2	Screw Flat Head M3 L6
16	16339-00651	1	Short Bar
17	0515-0924	2	Screw Pan Head M3 L6

<sup>1</sup> Hidden by Panel Assembly.

<sup>2</sup> included in Flat Table.

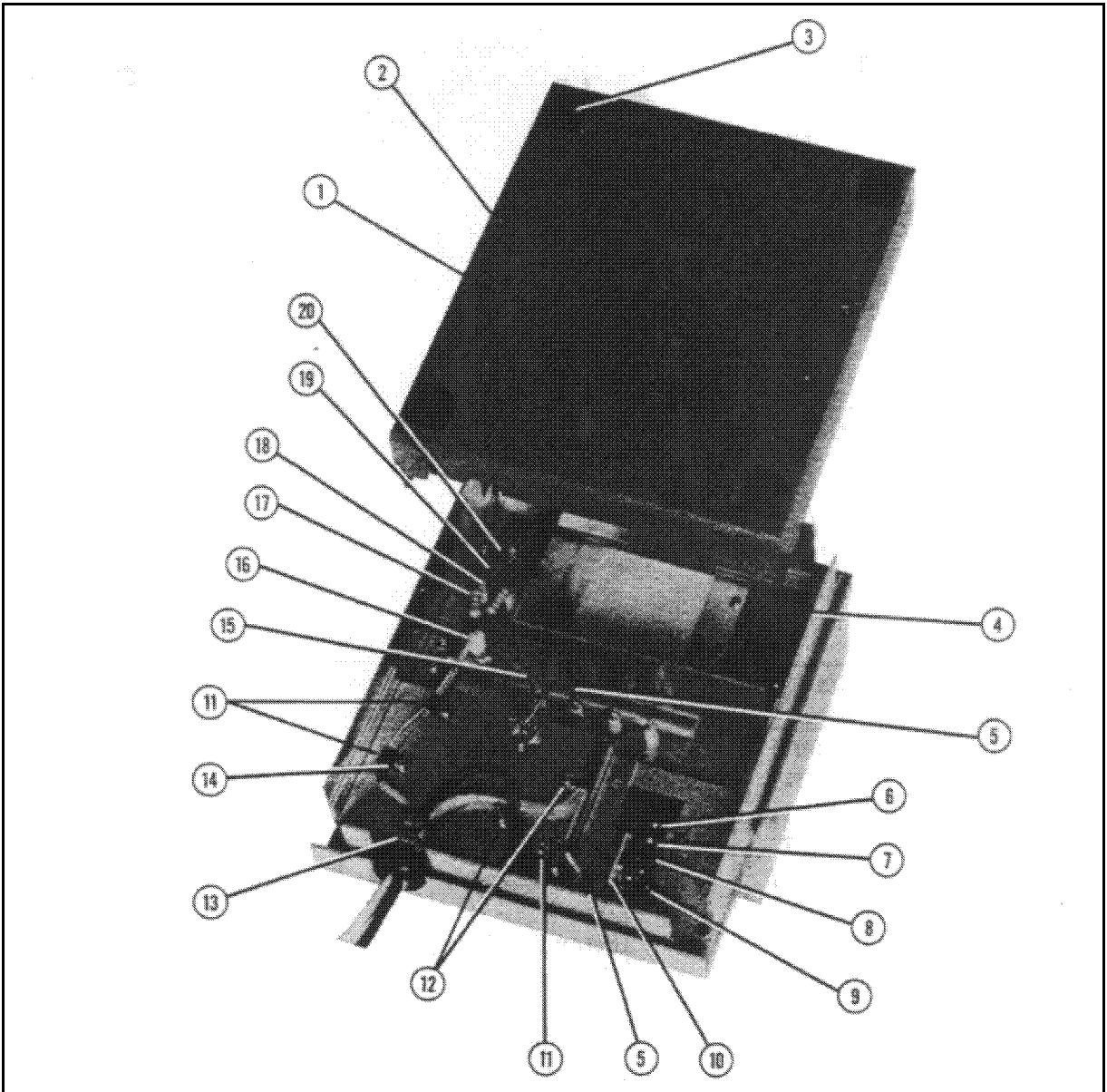

Figure 4-2. Main Body Replaceable Parts (3 of 3)

**Table 4-4. Main Body Replaceable Parts (3 of 3)**

<b>Reference Designator</b>	<b>Agilent Part Number</b>	<b>Qty.</b>	<b>Description</b>
1	16008-60053	1	Bottom Cover
2	0515-0914	2	Screw Flat Head M3 L6
3	0403-0424	4	Cushion 20.6×7.6
4	16339-00101	1	Chassis Assembly
5	16339-68022	2	J.W.L
6	0515-1087	1	Screw Pan Head M3 L14 (for micro switch)
7	0535-0031	1	Nut
8	3101-0302	1	Micro Switch
9	0515-0920	2	Screw Pan Head M3
	2190-0584	2	Washer
	3050-0891	2	Washer
10	16339-01211	1	Angle Bracket
	0515-0914	2	Screw Flat Head M3 L6
11	1400-0054	3	Clamp, Cable
12	1400-0015	2	Clamp, Cable
13	1400-0493	2	Cable Tie
14	0515-2079	5	Screw Pan Head M4
15	16339-68023	1	J.W.L
16	16339-60012	2	Terminal Assembly
	2950-0043	2	Nut
17	0764-0045	2	Resistor 22 K 2 W
18	16339-25010	1	Stud
19	16339-00611	1	Terminal Plate
	0515-0924	1	Screw Pan Head M3 L6
	3050-0891	1	Washer
20	1901-0880	4	Diode

## Assembly Replacement (Axial Lead Module)

This section includes the Replaceable Parts list for the Axial Lead Module.

### Replaceable Parts

Table 4-5 identifies the replaceable parts for the Axial Lead module. To order the parts listed on this manual, quote the Agilent part number, indicate the quantity required, and address the order to the nearest Agilent Technologies office.

**Table 4-5. Axial Lead Module Replaceable Parts**

Reference Designator	Agilent Part Number	Qty.	Description
	16339-60102	1	Axial Lead Module <sup>1</sup>
1	16339-60013	1	Plate Assembly <sup>2</sup>
2	16339-68004	1	J.W.L
3	16339-68003	1	J.W.L
4	0890-0720	20 mm × 2	Tube, Heat Shrinkable
5	1200-1422	1	Socket
6	0515-2058	2	Screw, Plastic
7	16339-00605	1	Shield Cover
	0515-0914	3	Screw Flat Head M3 L6 (for Shield Cover)
8	1390-0366	2	Snap-In Grommet
9	1390-0365	2	Snap-In Plunger

<sup>1</sup> The whole unit.

<sup>2</sup> includes connectors.

---

## **Assembly Replacement (SMD Module)**

This section includes Disassembly and Assembly Procedures and the Replaceable Parts List for the SMD Module.

### **Disassembly and Assembly Procedure**

#### **SMD Module Disassemble Procedure:**

1. Loosen the three screws on the cover and remove the cover.
2. Unsolder the wires from the terminals.
3. Remove the fixed electrode assembly and the block by loosening the inside screws.
4. Remove the movable electrode assembly.
5. Remove the screw which attaches the spring lever.

#### **SMD Module Assemble Procedure:**

1. Attach the spring lever.
2. Set the movable electrode assembly in the gap of the spring lever.
3. Tighten the screws holding the movable electrode assembly.
4. Attach the block.
5. Attach the fixed electrode assembly.
6. Attach the cover.

## Replaceable Parts

Table 4-6 identifies the replaceable parts for the SMD Module. To order the parts listed in this manual, quote the Agilent part number, indicate the quantity required, and address the order to the nearest Agilent Technologies office.

**Table 4-6. SMD Module Replaceable Parts**

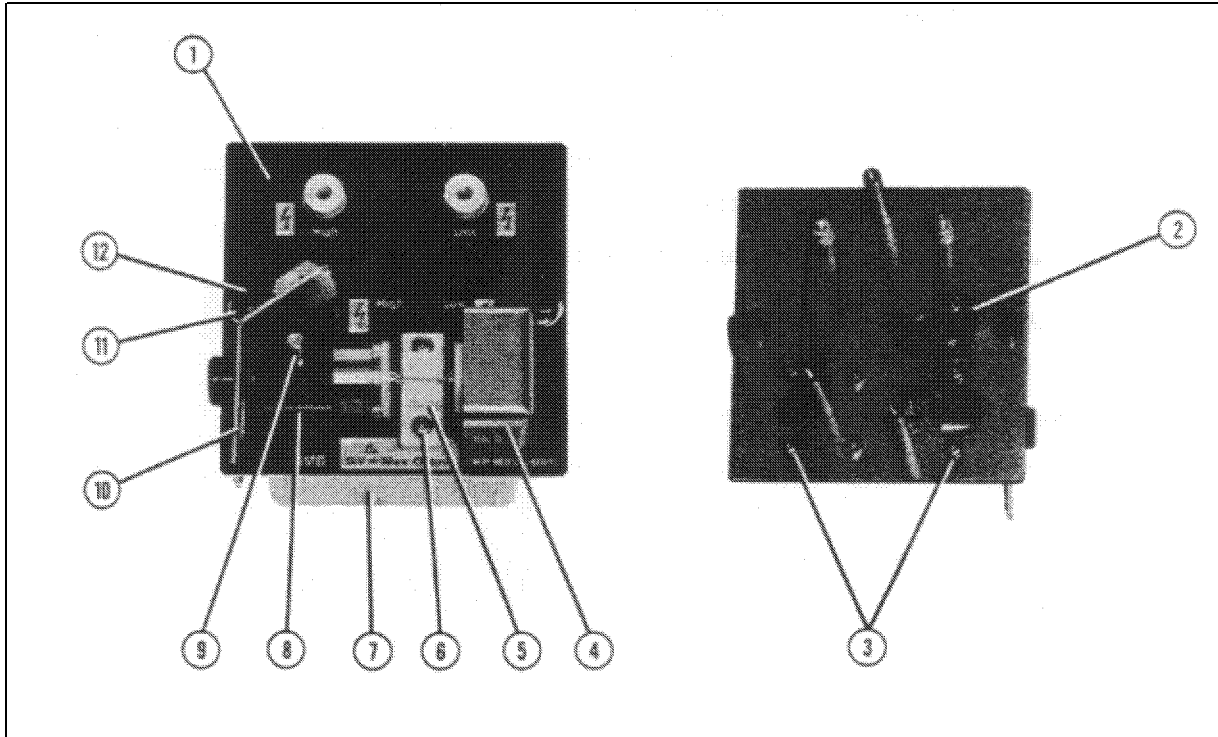

Reference Designator	Agilent Part Number	Qty.	Description
	16339-60101	1	SMD Module <sup>1</sup>
1	16339-60014	1	Plate Assembly <sup>2</sup>
2	0515-0924	1	Screw Pan Head M3 L6
	3050-0891	1	Washer
	16339-00607	1	Plate
	42851-24023	3	Washer
	42851-29021	1	Spring
3	0515-1550	4	Screw Pan Head (for electrodes)
4	16339-60015	1	Electrode Assembly, Fixed
5	16339-25002	1	Block
6	0515-1552	2	Screw Pan Head M3 L12 (for block)
7	16339-00601	1	Shield Cover
	0515-0914	3	Screw Flat Head M3 L6 (for Shield Cover)
8	16339-60016	1	Electrode Assembly, Movable
9	16339-23004	1	Screw
10	16339-05001	1	Lever
11	1390-0366	2	Snap-In Grommet
12	1390-0365	2	Snap-In Plunger

<sup>1</sup> The whole unit.

<sup>2</sup> includes connectors.



---

## Troubleshooting

This section gives cable connections and the schematic diagram of the 16339A.

### Cable Connection Check

After repairing, check the cable connections listed in \*\*\*<xref CONNECTION>: undefined\*\*\* and Table 4-7 using a multimeter which has a low resistance range (1 or 2  $\Omega$ ). The information in these lists can be also used for troubleshooting the 16339A.

### BNC Cable and Triaxial Cable Connection Check

Check the connections between the connectors and the terminals as shown in Figure 4-3.

---

**Note**

Before checking the connections, the shorting bar should be attached to the *Output Resistor* terminals.

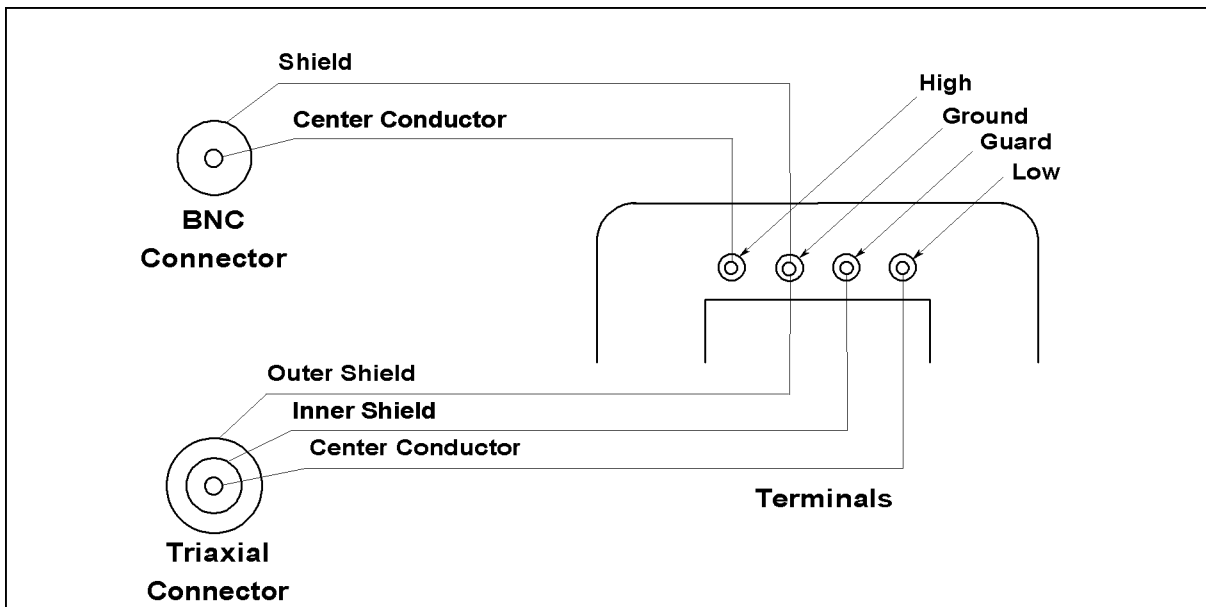

Figure 4-3. Cable Connection Check

## Interlock Circuit Connection Check

Interlock connector connections and its pin locations are shown in Table 4-7. Check the connections between each of the 6 pins and the outer conductor of the BNC connector or the Triaxial connector.

**Table 4-7. Interlock Circuit Connection**

Pin Number	Top Cover	
	Open	Close
1	NC <sup>1</sup>	GND <sup>2</sup>
2	GND	
3	GND	
4	GND	
5	NC	
6	GND	

1 Not Connected.

2 Connected to the chassis.

# Schematic Diagram

Figure 4-4 is the schematic diagram of the 16339A.

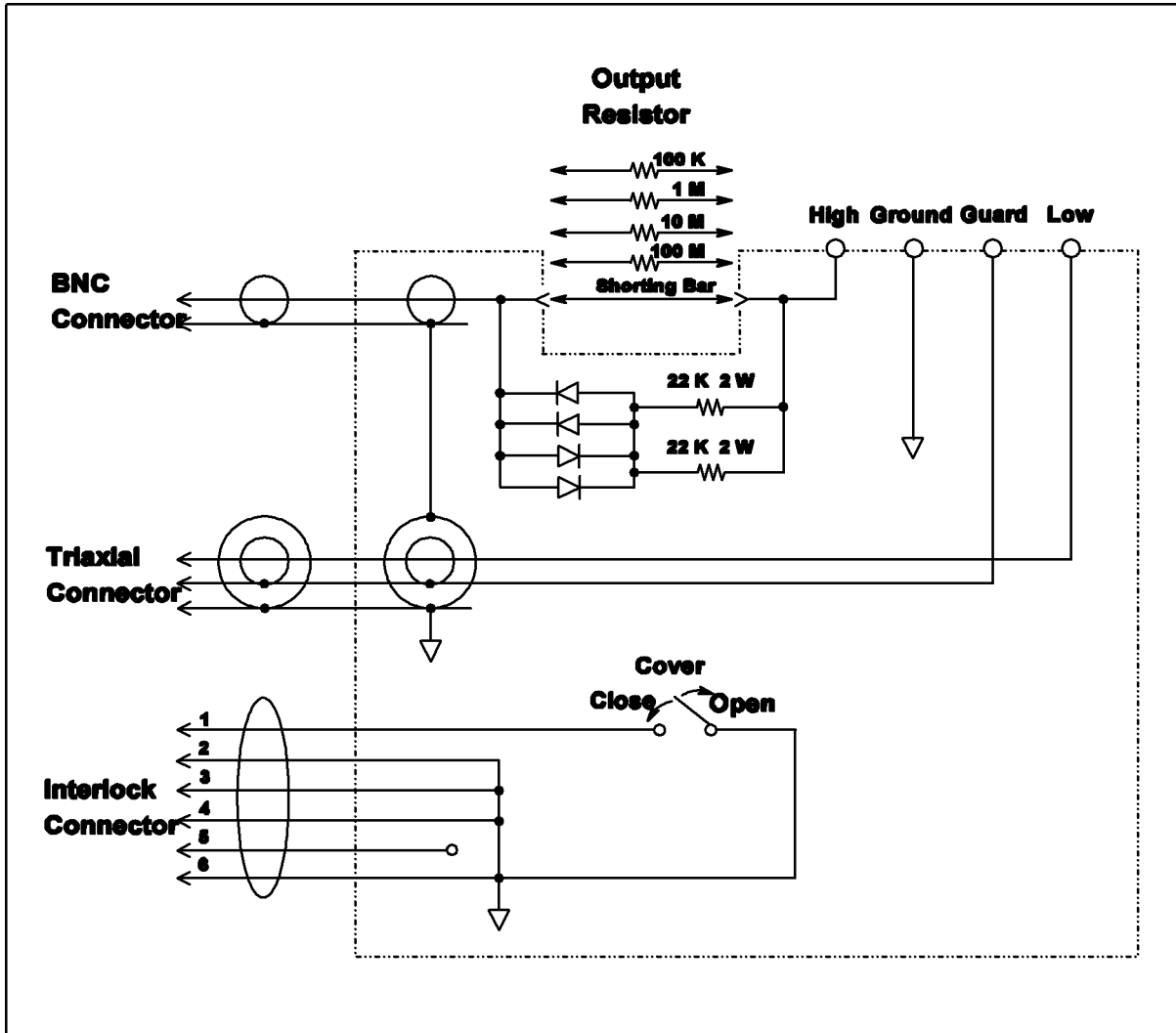

Figure 4-4. Schematic Diagram of the 16339A

